

Bearbeitung / Machining Cabineo HPL

Variante / Option 1:
Bohrer Ø 15,2 mm
Drill Ø 15,2 mm

A-A (1:1)

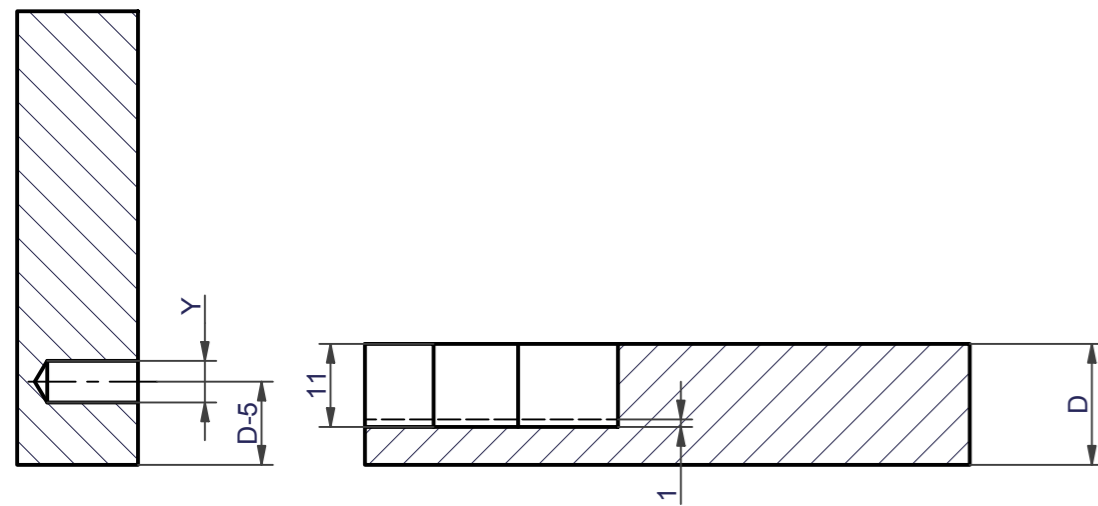

Variante / Option 2:
Fräser Ø10 mm oder kleiner
Cutter Ø 10 mm or smaller

B-B (1:1)

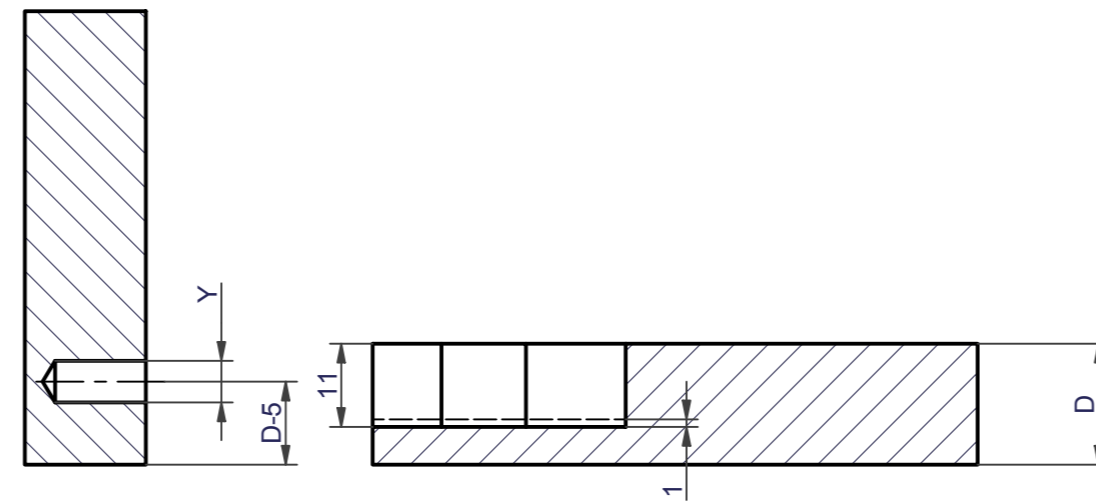

Variante / Option 3:
Fräser Ø 12 mm
Cutter Ø 12 mm

C-C (1:1)

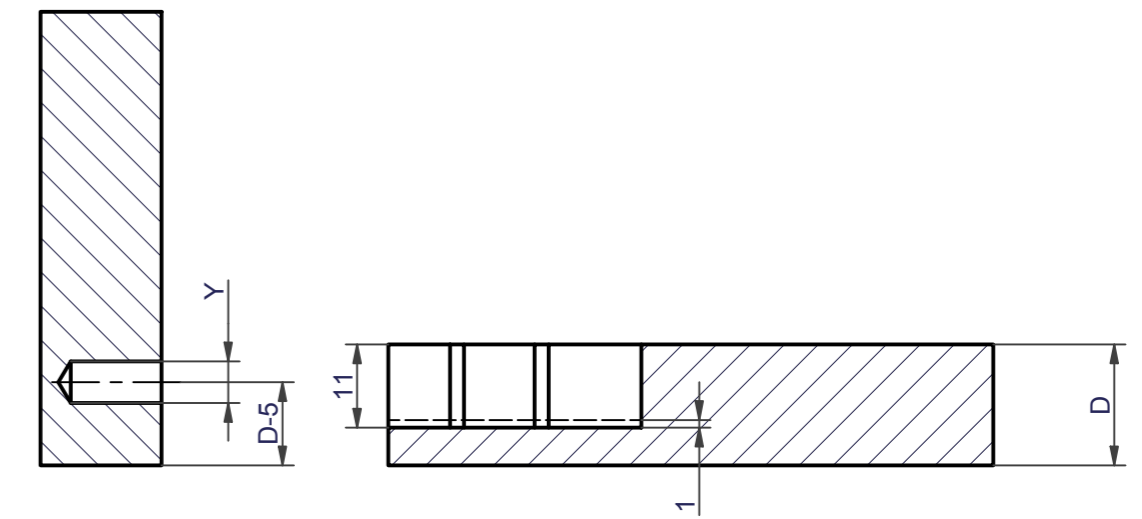

3,5 11,18 11,18

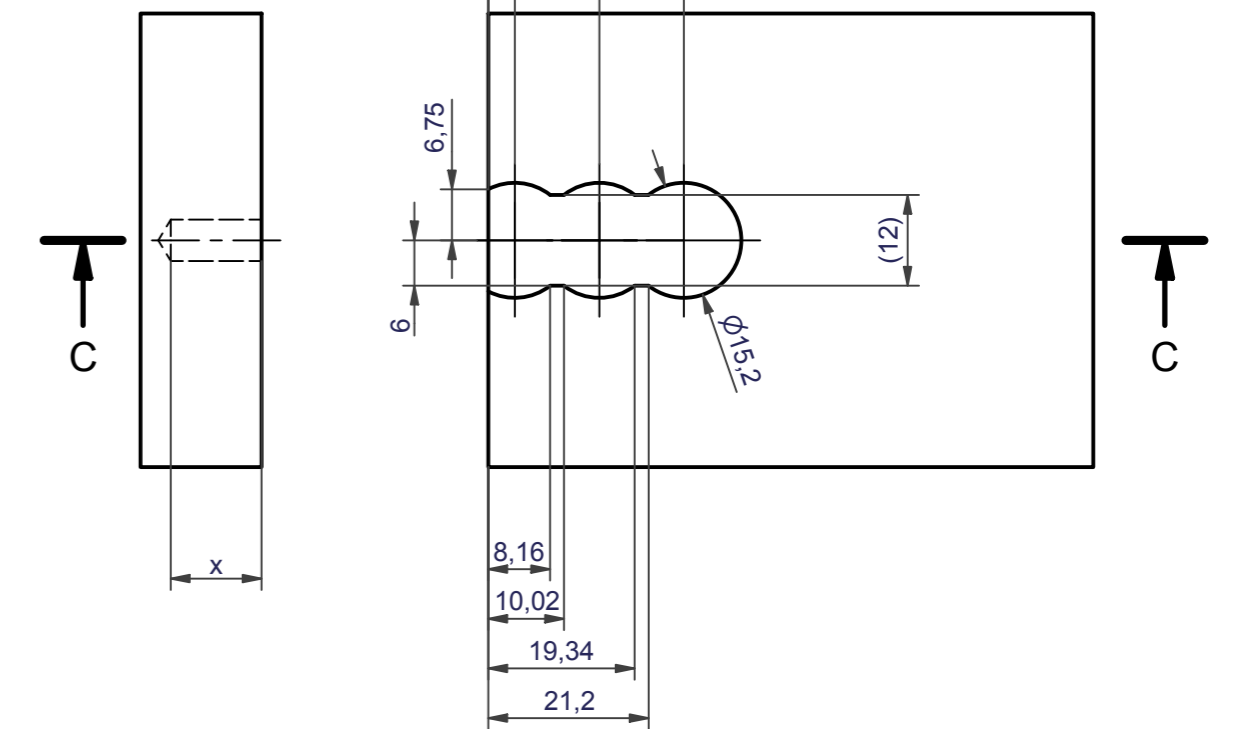
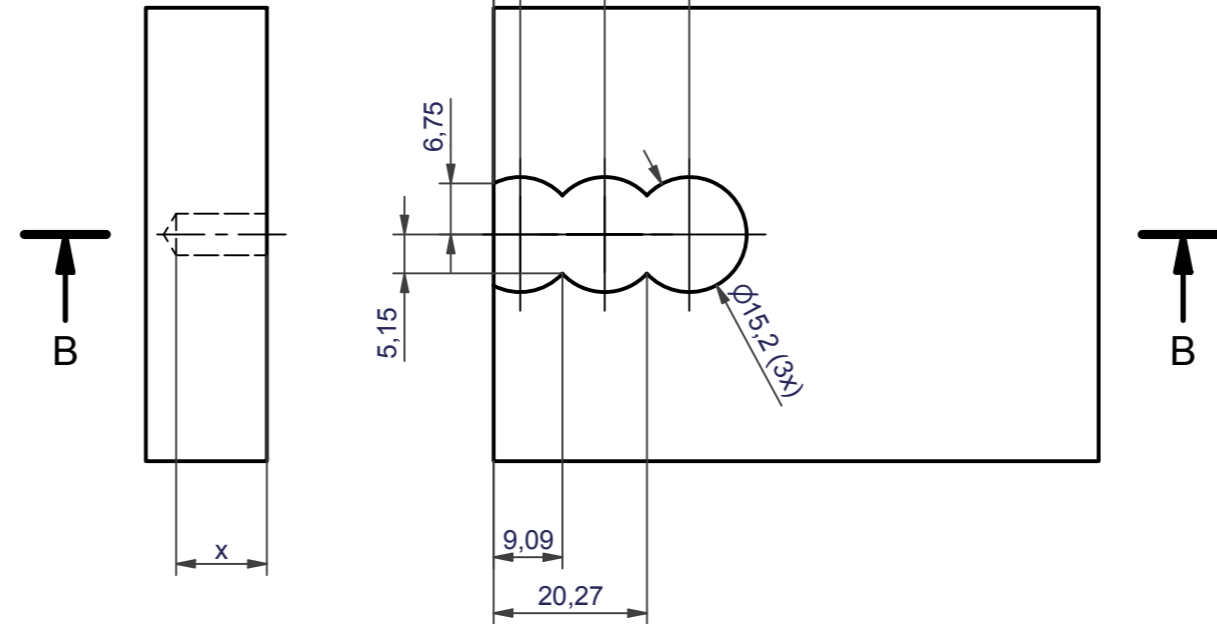
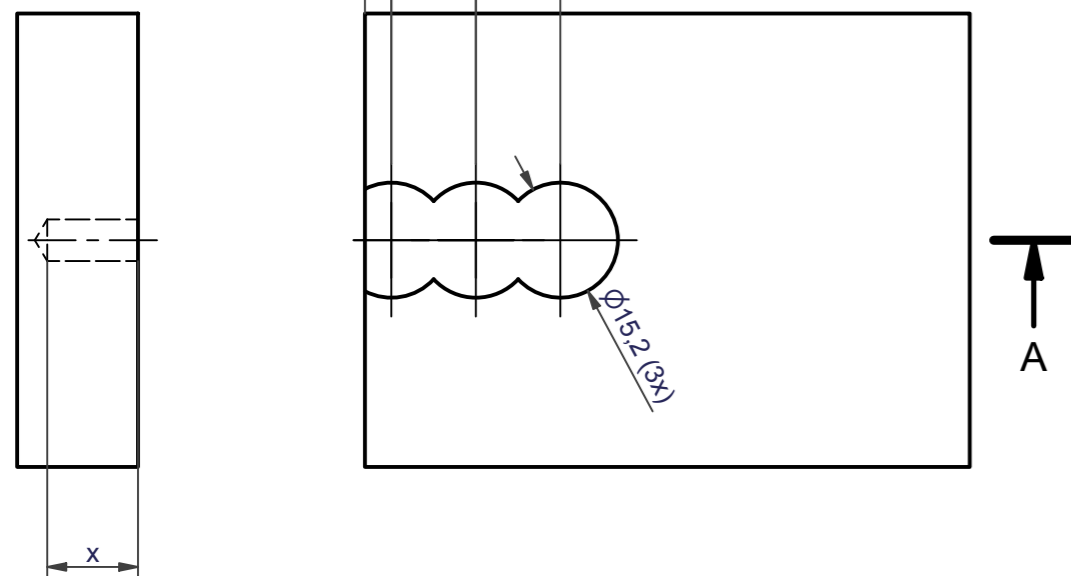

	X [mm]	Y=Ø [mm]
Cabineo 8	8	5,5
Cabineo 12	12	5,5
Cabineo 8 M6	8	M6 (Kernbohrung 5)